

FUNDAMENTALS OF THERMOMETRY  
PART IV  
MEASURING THE RESISTANCE OF  
STANDARD PLATINUM RESISTANCE  
THERMOMETERS

by Henry E. Sostmann

ABSTRACT

The Standard Platinum Resistance Thermometer, acronym SPRT, is the stipulated interpolation instrument for realizing the International Temperature Scale of 1990 between the defining fixed points, over the range from 13.8 K (the triple point of eka-hydrogen) to 961.78°C (the freezing point of silver). The transfer function of the SPRT is electrical resistance as a function of temperature; therefore an accurate measurement of resistance, referred to a fixed resistance base, is an essential component of the measurement chain. This article discusses fixed resistors, and then both traditional and modern means for making the resistance measurement.

1: FIXED RESISTORS

The ohm is now maintained, in most National Laboratories, as a quantum-Hall (QHE) effect device; the Von Klitzing ohm. In the apparatus which allows realization of the QHE ohm, semiconductor devices of standard Hall-bar geometry are placed in a large applied magnetic field at a temperature near 1 K. For an applied current through the device, there are regions where the Hall voltage remains constant, as a function of the fundamental constants  $h/e^2$  as the field or the gate voltage are varied. There are a number of such plateaus; the conventional value of the effective resistance of the first plateau is  $25\,813.807\ \Omega$  (1). This value is believed consistent with the SI ohm to within an assigned 1 $\sigma$  uncertainty of 0.2 ppm.

(The use of the QHE ohm in nations which are members of the Treaty of the Meter became effective on January 1, 1990, replacing at NIST the NBS ohm of 1948. The relationship is:

$$1\ \Omega(\text{NBS-48}) = 0.99999831(\text{NIST-90})$$

Thus the ohm is now realized as a universal constant independent of the variables of experiment. This is much more satisfactory than the earlier definition, where the ohm is a quantity derived from the fundamental SI units as  $\Omega = \text{kg}\cdot\text{m}^2/(\text{A}^2\cdot\text{s}^2)$ , or the still earlier definition in terms of the electrical properties of a column of mercury.

Prior to the adoption of the QHE ohm as a standard representing a fundamental constant, the ohm was maintained in most National services as the mean resistance of a bank of 1  $\Omega$  resistors (usually 10), which were, or were generally similar to, the 1  $\Omega$  resistor developed by Thomas at the NBS (2). Because of the cost and complexity of maintaining the QHE ohm, it is highly probable that most laboratories which are not National, and many National Laboratories in smaller nations, as well as scientific and industrial organizations in the private sector, will continue to rely on the Thomas-type 1  $\Omega$  resistor to maintain the local standard of the ohm, and it is to these that the fixed resistors which are the reference basis for platinum resistance thermometry will be referred.

The primary requirement for a resistance standard is permanence of value with respect to time and use. (I do not include accurate knowledge of the resistance, since every standard resistor must be accompanied by a valid and up-to-date calibration certificate). (In the unusual case where all measurements will be made using the same fixed resistor and bridge, and there is no need to report a calibration that is to be transferrable to another set of fixed resistor and bridge; that is, where results in terms of bridge units for a specific bridge are all that is desired, stability may be the only paramount requirement). Secondary and highly desirable characteristics are (a) a low and stable temperature coefficient (b) a low thermal e.m.f with respect to copper in the external circuit (c) a design which permits dissipation of the  $I^2R$  heating due to the passage of the measuring current (d) low or zero reactance, which can also be characterized as a fast time constant in response to an impressed input. (d) is of particular interest when the resistor is used as the standard resistor of modern automatic resistance bridges or comparators, most of which operate at low ac frequencies.

As a generality, all resistors which can be considered as reference standards use bulk wire as the resistance element. An exception to this is the resistor design of Vishay, which comprises a fine grid of metal laid as a thick film on a glassy substrate, in such a pattern that the adjustment of resistance to a precise value can be made by physically cutting certain conducting lines. The success of this scheme in resistors intended to be stable standards is not yet proven; there arise questions of, for example, strain developed because of the differing characteristics

of the deposited metal and the substrate. These resistors, however, have proven to be very valuable as highly precise circuit elements.

Various alloys are available for the bulk wire resistance element. Perhaps the most important of these is manganin, an alloy developed by Edward Weston in 1889. The composition is 84% copper, 12% manganese and 4% nickel. The resistivity at 20°C is about 48.3  $\mu\Omega/\text{cm}$  (290  $\Omega$  per circular-mil-foot). The temperature coefficient of resistance is about  $\pm 0.000015 \Omega/\Omega/^\circ\text{C}$  over the normal laboratory range of 15° to 35°C, although it varies from lot to lot for reasons which are not well understood or predictable. It can be adjusted somewhat by heat-treatment in fabrication. For precise work, the temperature of the resistor must be noted and a correction made. The calibration certificate of the specific resistor should include the measured coefficients of the correction equation, which assumes standardization at 25°C.

$$R_{t_1} = R_{25}[1 + \alpha(t_1 - t_{25}) + \beta(t_1 - t_{25})^2]$$

For properly selected manganin,  $\alpha$  generally has a value smaller than  $10 \times 10^{-6}$ , and  $\beta$  between  $-0.3 \times 10^{-6}$  and  $-0.8 \times 10^{-6}$ . Fig. 1 shows a typical curve of resistance versus temperature for good manganin. The most desirable situation is that the peak of the curve be located very close to the laboratory ambient temperature, so that any effects of  $I^2R$  heating have minimum influence on the resistance. A further precaution is to maintain standard resistors in thermostated oil or air baths. Oil baths, in particular, also assist in dissipating any self-heating. The thermoelectric power versus copper is low; 2 to 3  $\mu\text{V}/^\circ\text{C}$ .

In constructing manganin resistors, it is particularly important that where the manganin joins internal copper lead wires, the joint be made by welding, or brazing with suitable materials. The components of soft-solders can, with time, migrate into the manganin wire structure and cause irreversible alloy (and consequently resistance) changes.

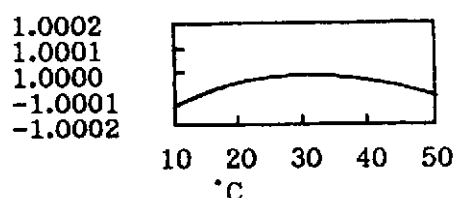

FIG. 1

MANGANIN: Typical change in resistance with temperature for selected wire

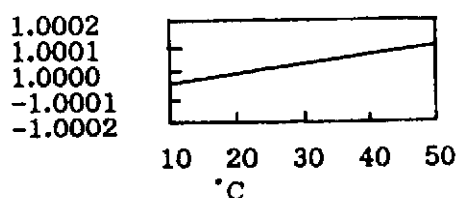

FIG. 2

EVANOHM: Typical change in resistance with temperature

Another resistance wire alloy in common use is known by the trade names Evanohm and Karma. Its major advantage is a high specific resistance, 800  $\Omega/\text{cmf}$ , which permits all resistors to be made of wire of larger cross section than manganin, and consequently of better mechanical stability in situations of normal shock, vibration, etc. incidental to use. The composition of the alloy is about 75% nickel, 20% chromium plus a few per cent each of aluminum and copper. The temperature coefficient is about  $\pm 0.00002 \Omega/\Omega/^\circ\text{C}$  but there is no peak such as that of manganin. Fig. 2 shows a typical curve for Evanohm.

I cannot comment from personal experience on the resistance stability of Evanohm relative to that of manganin. I can mention that manganin is a solid solution of its constituents, while Evanohm is an intermetallic; that is, some of the elements of the alloy remain as discrete crystals. From experience long ago in using potentiometer wires which contained aluminum, I can report that as surface crystals it is subject to eventual oxidation, which in potentiometers caused local spots of high contact resistance, and in standard resistors may be a source of calibration drift. Nevertheless the Australian laboratory CSIRO has made 1  $\Omega$  Thomas-derivative resistors of Evanohm with remarkably small changes in resistance over a number of years. The composition of Evanohm suggests that all joints to copper be made by welding, since it is difficult to wet chromium and aluminum with soft solders, and the migration problem is probably equivalent to that with manganin.

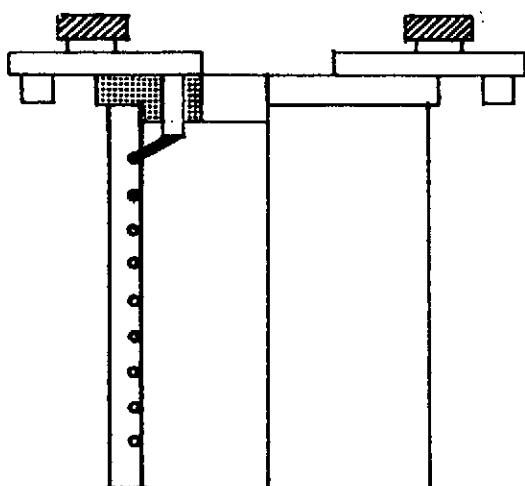

FIGURE 3  
A Thomas 1  $\Omega$  Resistor  
(After Leeds and Northrup)

The basic design of the Thomas 1  $\Omega$  resistor is shown in Fig. 3. Manganin wire of heavy gage is wound on a temporary mandrel in a bifilar fashion with spaced turns. The wire is bare, so that full heat treatment (at  $550^\circ\text{C}$  in an inert atmosphere) may be applied, as would not be permissible were the wire enamelled or served with a textile fiber serving. After heat treatment, the helix is slipped onto a silk-insulated metal cylinder and sealed into a dry double-walled container. The wire gradually reaches equilibrium with the slight amount of contained dry air.

Such a resistor is capable of stability of 1 part per million over several years. The construction is not optimal for heat transfer, and so any impressed current must be carefully limited. There is some slight effect on resistance from changes in barometric pressure, and the calibration certificate will furnish information about this.

While the 1  $\Omega$  Thomas-type resistor will be regarded by most users as the reference base for the ohm, it is not a very useful value for most resistance thermometry, where it is more desirable to have a reference resistor whose value is in the vicinity of, for example, the resistance of the thermometer at 0°C. For a 25.5  $\Omega$  thermometer this might be 25  $\Omega$ ; for an 0.25  $\Omega$  thermometer, 0.25  $\Omega$ , with 1  $\Omega$  another choice. Also, one would not wish to use the laboratory's standards base as a working standard. Most laboratories will maintain the 1  $\Omega$  standard and possibly an equivalent 10 k $\Omega$  standard built to the general Thomas design, and use these to build up and build down, by ratiometric methods, to the working standards of more convenient value.

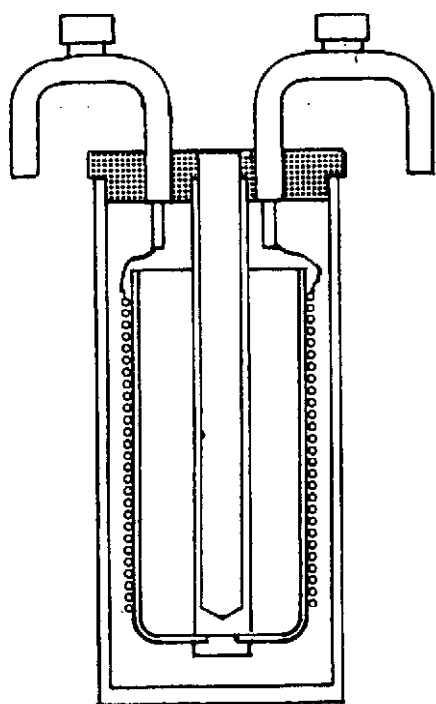

FIGURE 4

A ROSA, OR NBS TYPE RESISTOR. The space within the housing and around the thermometer well is filled with neutral oil.

A design of working standard which has proven itself through the years is that of Rosa, also known as the NBS-type resistor, shown schematically in Fig. 4. The resistance wire, which is manganin for at least the values of 10 K $\Omega$  and lower, is insulated with either enamel or a special textile fiber in which cotton and silk are mixed (this mixture said to provide minimal strain to the manganin it covers when the fiber is subjected to changes in ambient humidity). The wire is doubled at its midpoint and wound in bifilar fashion onto an insulated brass bobbin (a material chosen because the thermal expansion coefficient of brass closely matches that of the wire, and because it aids in heat dissipation).

The ends of the winding are brazed to a pair of short heavy copper leads, the free ends of which are connected to massive terminals. Externally, four connections are provided, a potential connection and a current connection to each end of the resistance winding, so that the resistor may be connected four-terminal.

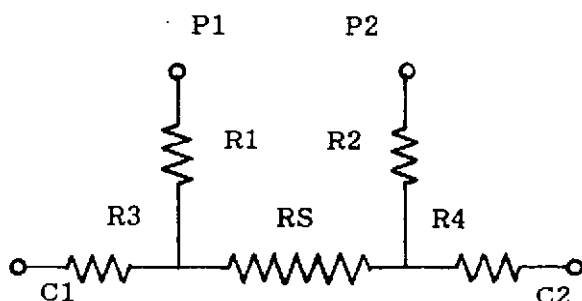

FIGURE 5

A FOUR-TERMINAL RESISTOR.  $R_S$  is the resistance to be measured.  $R_1$ ,  $R_2$ ,  $R_3$ ,  $R_4$  are external resistances; e.g., lead resistances.  $C_1$ ,  $C_2$  are current terminals,  $P_1$ ,  $P_2$  potential terminals. For an SPRT these are conventionally labeled  $c$ ,  $C$ ,  $t$ ,  $T$  respectively.

A four-terminal resistor schematic is shown in Fig. 5. The value of the four-terminal resistor is the potential difference between the potential terminals divided by the current through the current terminals, so that external circuitry is not a part of the measured resistance. The potential and current terminals are interchangeable. For both Thomas and NBS-type standard resistors, the potential terminals are usually binding posts and the current terminals are connected into the circuit using massive mercury-wetted amalgam contacts.

The finished winding assembly must be stabilized by heat treatment, and this process cannot be carried out to completion; the temperature at which the wire would be rendered ideally strain-free is higher than the insulation will tolerate. Thus it is of great importance to avoid ever impressing sufficient current on the finished resistor to heat the winding appreciably, or additional annealing may occur, with a permanent shift in value. During the production anneal, the value may decrease permanently by as much as 1% or 2%, and this must be allowed for in the winding length. The final adjustment of resistance is made coarsely by removing wire, and fine adjustment by reducing the wire cross-section, locally, by abrasion.

Rosa resistors are filled with a bland neutral oil, which assists in dissipating and transferring heat. They are equipped with a central well, into which a thermometer is placed to measure, with very close approximation, the coil temperature. A typical manufacturers' specification for stability is 20 ppm per year, which is, in my experience, highly conservative for a unit which is handled carefully.

Safe operating currents are stipulated by the manufacturer. These values should be posted on labels, and well-known by operating personnel. The use of an air or oil bath will increase the safe operating current limit, as well as provide temperature stability.

As far as I know, the principle supplier in the US of Rosa-type resistors, Leeds and Northrup, has never qualified or made a statement about the ac properties of these or the Thomas 1  $\Omega$  resistors of their manufacture.

NIST does not at this time offer a calibration of standard resistors which includes a comparison of dc with low-frequency ac characteristics, although, according to a telephone conversation (November 1991) with Norman Belecki of the Electricity Section, it plans to do so "in about a year". The National Physical Laboratory (NPL) of England has been offering this service since 1987. Resistors submitted by Isotech to NPL, which are used in conjunction with ac bridges for thermometry, are reported including a ratio of  $R_f/R_{dc}$ , where  $f = 75$  Hz. Fig. (6) reproduces a typical calibration report.

## 2: STANDARD RESISTORS USED WITH ALTERNATING CURRENT

Many modern devices for measuring the resistance of an SPRT operate in a semi-automatic or automatic fashion, based on principles which require that the signal received from the bridge be ac. Usually it has been possible to arrange circuitry allowing the frequency to be very low, with an upper bound of 400 Hz and a lower as low as 15 Hz. (I except an experimental bridge of Cutkosky which operated at 1/2 Hz, but which was never commercially available.)

The reactances of reference resistors are a function of their inductances (from the area included within the winding loop where the wire is doubled) and distributed capacitance. In general the inductance is small but the capacitive reactance is not, although it may be reduced by such devices as dividing the coil into sections. Reactance may include effects of the mandrels on which the winding is supported. The time constant of a resistor may be expressed as

$$\tau = (L - CR^2)/R$$

and may also be expressed as the time required for the current to reach  $1/e$  of its final value after a fixed voltage is impressed. Obviously, for a-c bridge service, the time constant must be short enough to allow the full value to be achieved within 1 ppm or 0.1 ppm.

NATIONAL PHYSICAL LABORATORY  
Teddington Middlesex TW11 0LW England

# Certificate of Calibration

STANDARD RESISTOR

No 248712 10 OHM H TINSLEY AND CO LTD



FOR : Isothermal Technology Limited  
Pine Grove  
Southport  
Merseyside PR9 9AG

REFERENCE: Order No. 90P0065/10 dated 11 May 1990

BASIS OF TEST: NPL Measurements Services - Direct Current and Low  
Frequency Electrical Measurements (1987). Section 3.2

PREVIOUS  
CERTIFICATE: None

MEASUREMENTS :

The resistor was immersed in an oil-bath controlled at a temperature of  $20.000 \pm 0.005^\circ\text{C}$  for at least 2 hours prior to and during the measurement and was measured in a 4-terminal configuration. The power dissipated in the resistor was less than 1 mW.

<u>Resistance</u>	<u>Uncertainty</u>	
	1 Confidence Level at least 95%	2 Arithmetic Sum of Contributions
9.999 917 ohm	$\pm 0.25$ ppm	$\pm 0.43$ ppm

The uncertainty of the measurement is quoted in two ways :

(1) At "A Confidence Level of at least 95%" - where the individual contributions have been combined in quadrature where appropriate.

(2) As expressed on certificates prior to October 1989 - where the individual contributions have been added arithmetically, "Arithmetic Sum of Contributions".

These uncertainties refer only to the measured value and do not carry any implication regarding the stability of the instrument.

Reference ES 94.69  
ES 7556  
Checked N.D.

Date of  
calibration 7 June 1990

Page 1 of 2

Signed

for Director

*This Certificate may not be published except in full, unless permission for the publication of an approved extract has been obtained in writing from the Director. It does not of itself impute to the subject of calibration any attributes beyond those shown by the data contained herein.*

ADM/16/87



NATIONAL PHYSICAL LABORATORY  
Continuation of Certificate

AC/DC STANDARD RESISTOR

No 248712 10 OHM H TINSLEY AND CO LTD

RESULTS:

Test frequency Hz	$R_f/R_{dc}$	Uncertainty	
		1 Confidence Level at least 95%	2 Arithmetic Sum of Contributions
75	1.000 000	± 0.9 ppm	± 2.4 ppm
	$\tau : \mu\text{H}/\Omega$		
	0.10	± 0.015 $\mu\text{H}/\Omega$	± 0.02 $\mu\text{H}/\Omega$

The resistor was inductive.

The uncertainty of the measurement is quoted in two ways :

(1) At "A Confidence Level of at least 95%" - where the individual contributions have been combined in quadrature where appropriate.

(2) As expressed on certificates prior to October 1989 - where the individual contributions have been added arithmetically, "Arithmetic Sum of Contributions".

These uncertainties refer only to the measured value and do not carry any implication regarding the stability of the instrument.

Reference EtA 534.198

ES 7557

Checked N.D.

Page 2 of 2

Date of

calibration 18 June 1990

Signed



Details of design can be used to reduce residuals; for example splitting the wound coil into two sections connected in series can reduce the capacitance by a factor of 4. Many designs other than that of Fig. 4 have been proposed to eliminate residuals over a desired band of frequencies. These include flat single-layer windings on card-shaped mandrels, for example of sheet mica. Produced by, for example, Electro-Scientific Industries of Portland, Oregon, these have formed the basis of a large number of commercial bridges, decade boxes, and the useful and familiar Dekapots and Dekastats. Other approaches include windings which pass through a slotted ceramic core and reverse direction with each turn, etc. Difficulty in manufacture has prevented these from becoming widely used. High resistance elements have been produced commercially in which the winding is a flat woven web, or patch, with a resistance-wire warp and a textile-fiber woof, and these have been used for many years in certain Leeds and Northrup standard resistors, above the range of interest for platinum resistance thermometry.

A number of workers in the last several decades have attempted to design standard resistors to give the same value for low-frequency ac (dc to several kHz). A successful configuration has been described by Wilkins and Swan (3). This general configuration is available from H. Tinsley & Co. Ltd. (4). It is a Tinsley resistor which is the subject of the NPL Calibration Report shown in Fig. (6).

Wilkins identifies a number of factors which determine the frequency characteristic of a resistor. These include thermoelectric effects resulting from the nature of the resistance wire alloy, inductance and capacitance of the resistor resulting from the arrangement of the resistive element, and eddy current and dielectric losses resulting from the mounting and housing and from the disposition of current and potential lead wires. All of these require consideration in design for ac use.

Many resistive alloys have thermoelectric properties versus copper. When alloy to copper junctions are not at the same temperature, these effects present themselves as (a) Seebeck effects, in which a voltage is generated in opposition to the voltage impressed upon the resistor for the sake of measurement (b) Peltier effects, in which the passage of a direct current through a junction of dissimilar metals causes heating or cooling at the junction (c) Thompson effects, in which a voltage is developed between points along a wire of uniform composition with a temperature gradient along its length. These effects may combine in various senses and serve to make a measurement of pure resistance indeterminate. In these cases, the true value of resistance is measurable only at the instant that the circuit is energized, and another value may be measured when the circuit values have stabilized. The indications for

resistor design are that (a) resistance wires with low Siebeck coefficients should be chosen (b) the physical design should exert every effort to maintain the alloy-to-copper and the winding itself in an isothermal condition.

In general, the reactance of low-ohm (up to 500  $\Omega$ ) resistors is inductive, and almost any reasonable value of capacitance is acceptable. It is, however, desirable to keep the inductance low, since the phase angle between applied voltage and current is largely due to the ratio  $L/R$ . Low inductance indicates as short as possible a length of wire in the bifilar helix; a condition which, for a given resistance, requires wire of small diameter. This is at odds with mechanical stability, which argues for large diameter wire, and so a compromise is required.

With careful consideration of all the above factors, Wilkins has produced resistors whose dc and ac resistances are the same within 0.1 ppm to frequencies as high as 1.6 kHz.

### 3: AC: POSSIBLE EFFECTS ON SPRTS

An SPRT winding is not mechanically or electrically dissimilar from the winding of a standard resistor. It is a spaced bifilar winding in which the current path is in one direction for approximately half of the winding and reverses for the other half, so that it approximates a non-inductive winding, but may be capacitive. Many precise measurements of both Leeds and Northrup pattern SPRTs and those manufactured by Isothermal Technology seem to indicate that these effects are sufficiently small so that the measurement deviation due to electrical reactance is not more than 0.1 part per million at low impressed frequencies, compared to d-c measurements.

(At high temperatures other a-c effects have been noted. Studies of the best insulations used for the formers on which SPRT windings are supported indicate that the degradation of the insulating properties of quartz and sapphire is marked. I have measured insulation resistance in a thermometer of 120  $M\Omega$  per square at 960°C, which drops to about 20  $M\Omega$  per square at 1100°C. 20  $M\Omega$  of random shunt resistance cannot be ignored, and this effect is a prominent reason why ITS-90 terminates the SPRT range at the silver freezing point (961°C) instead of the gold freezing point (1064°C.) Such a shunt effect would be, of course, as undesirable with dc as with ac, but much of the effect seems to be due to a long time-constant polarization, so that resistance rises over a time which may be measurable in minutes. Thus the recovery of most of the insulation resistance would take place with a direct current impressed, but might not within the reversal time of an alternating current.

## 4: DC BRIDGES FOR RESISTANCE THERMOMETRY

Resistance measurements can be made by deflection (magnitude of the unbalance of a circuit which is balanced at some value) or by balance. Deflection methods are never used in the precise determination of resistance (except as the deflection of the galvanometer is used to further quantify the last place on the bridge dials).

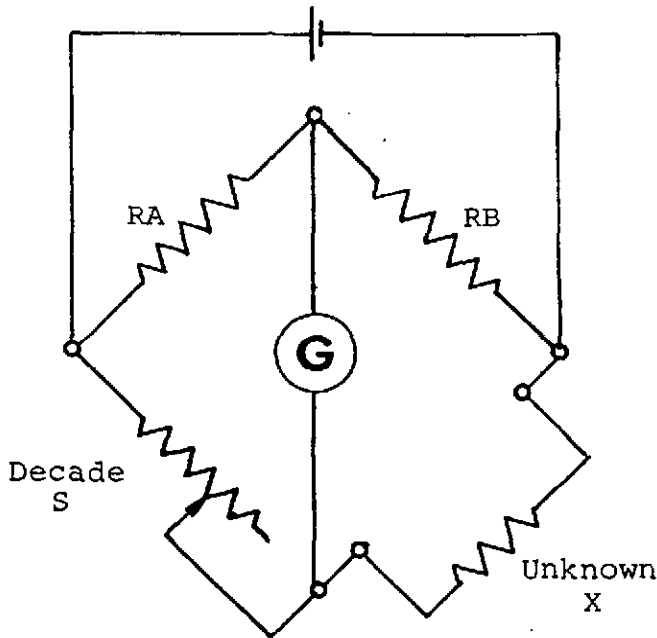

FIGURE 7

A WHEATSTONE BRIDGE

An elementary (Wheatstone) bridge is shown schematically in Fig. 7, where A and B are fixed resistors (often of identical value, in which case the bridge is said to be "equal-arm", a resistance decade S, and an unknown resistance to be measured, X. At balance, when the unknown resistance is balanced by the decade resistance (assuming  $A = B$ ), the potential drop from Junction 1 to Junction 2 is equal to the potential drop from Junction 1 to Junction 4, so that  $i_{ab}A = i_{xs}X$ , and  $i_{ab}B = i_{xs}S$ . These equalities can be expressed as

$$A/B = X/S$$

which is the equation of balance for the Wheatstone bridge. At this balance, no current flows in the galvanometer arm G.

The equalities of the balance condition include the entire bridge circuit, including any external lead wires which extend to the resistance, X, which is the subject of the measurement. These external resistances may be negligible, for example if X is very large in comparison with  $R_{11}$  and  $R_{12}$ , but in an elementary bridge, they are always a component of the measurement in series with X. In industrial resistance thermometry, lead resistances can be partially compensated, or almost completely compensated under specific restrictions, (e.g., by inserting a dummy loop of lead wire in the opposite side of the bridge), but must be eliminated for precise and standards-quality resistance thermometry. Figs. 8(a) and 8(b) show two methods for making such connections. Obviously, the

degree of compensation depends upon the other resistances in the circuit; for example, compensation is more closely approximated if the bridge is constructed with equal ratio arms.

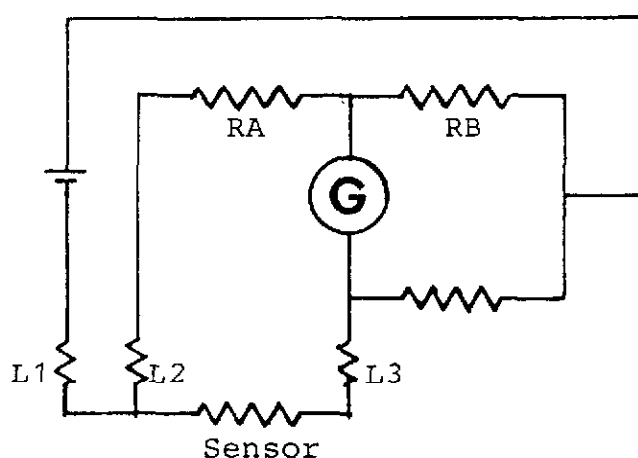

FIG 8A

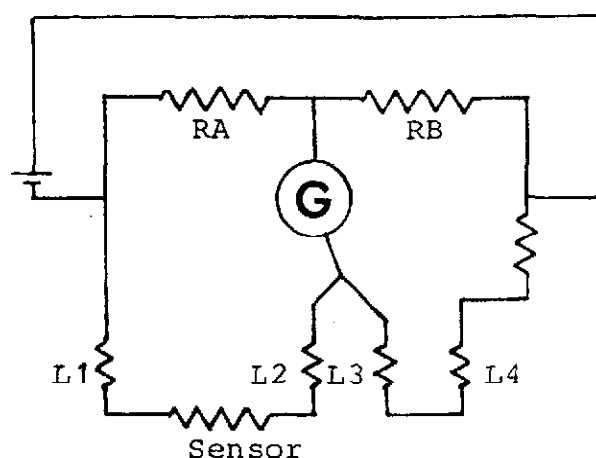

FIG 8B

Bridge connections for an industrial platinum resistance thermometer, providing partial lead resistance compensation. In 8A, (a 3-wire thermometer) L1 is in series with the battery, where it is effectively not a part of the bridge balance circuit. L2 is in series with RA, and L3 in series with the sensor. In 8B, (a 4-wire thermometer) L1 and L2 are in series with the sensor, while a dummy loop (L3 and L4) comprising a length of lead wire equal in resistance to L1 + L2 is in series with the bridge balance resistor. The degree of compensation depends upon the bridge values and the bridge unbalance.

#### 5: D-C BRIDGES: THE MUELLER BRIDGE

The most commonly used d-c bridge for four-terminal measurements of standard platinum resistance thermometers, from the time of its design in 1916 until the advent of more modern inductive bridges, was developed by Mueller at the NBS (5). McLaren's seminal work in developing the metal freezing points as calibration standards was done with an L&N Mueller G-2 Bridge (Mac calls it a G-2½, the ½ to recognize a least decade he added, and my own work on the gallium melt point was done with a Rubicon version of the G-2. The Mueller bridge represents a modified Wheatstone bridge with a range up to 81.111  $\Omega$ , 111.111  $\Omega$ , or 422.1111  $\Omega$  (6) full-range.

(Anyone visiting NIST will be interested to have a look into the Museum, which is rather well concealed behind a door to the right of the main

entrance to the Library, in the Administration Building. Many beautiful original devices are there on display, and among them is Mueller's first bridge, which he made with a sheet of marble as its top panel).

The bridge is always used with equal ratio arms of moderate individual resistance, e.g., 500  $\Omega$  or 3000  $\Omega$ . An small slide wire is provided which is used to balance these resistances exactly, by interchanging them. Once the arms are equal, the zero resistance value can be determined precisely. Commutators are supplied for these adjustments.

Consider the bridge circuitry shown in Fig. 9. (A complete diagram of the Leeds and Northrup G-3 Mueller Bridge is shown in Fig. 10). The four lead c, C, t and T of the thermometer are connected as shown, and are integrated into the bridge circuitry as follows:

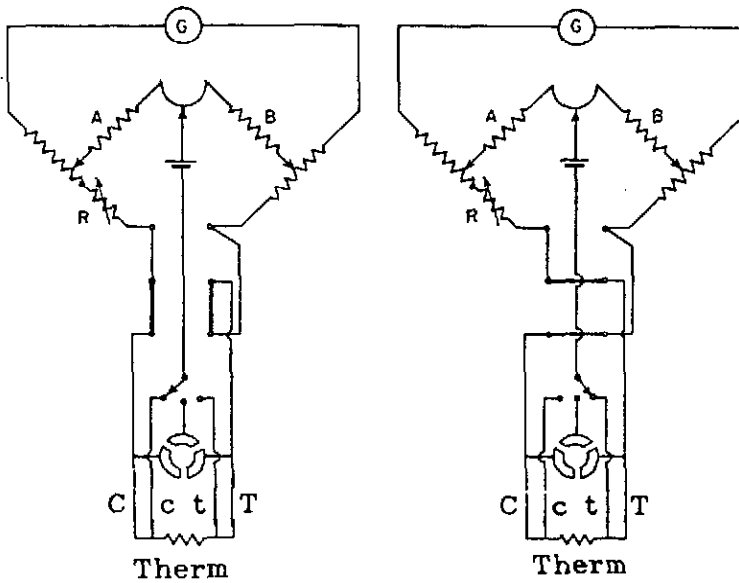

FIGURE 9

A schematic Mueller Bridge

In the commutator switch position of the left-hand circuit, lead c connects into the battery circuit, where its resistance is of no consequence. In the commutator position of the right-hand circuit, lead t is in the battery circuit. Potential leads C and T are in opposite lower arms of the bridge circuit, and are switched to the alternative arm by the commutator. Thus battery leads are exchanged and connections to the decade arm and the fixed arm of the bridge are exchanged simultaneously. The commutator is a switch whose contacts are mercury-wetted, which, if they are clean and in good condition, will add contact resistance of, at most, several microhms.

Since the bridge ratio is 1:1, if the C and T leads are equal in resistance, they will cancel each other, and the net resistance added to the X arm of the bridge is only the resistance of the thermometer coil. At the level of precision required of this measurement, leads C and T cannot be assumed to have equal resistance. A reversal of leads C and T

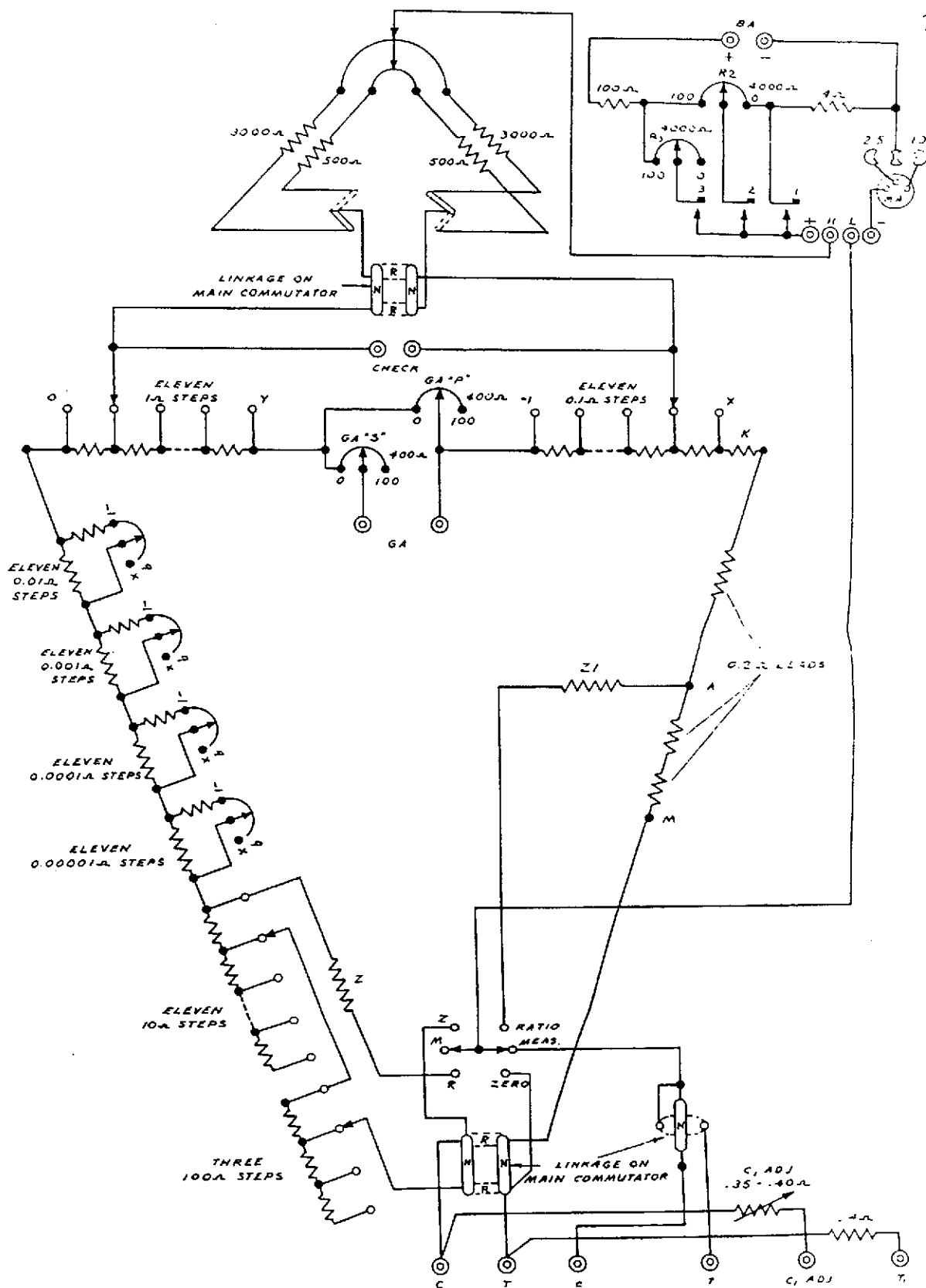

FIGURE 10

The complete circuit of the Leeds and Northrup G-3 Mueller Bridge. The least dial is  $10 \mu\Omega$ . Bridge arm resistances of 500 or 3000  $\Omega$  may be chosen. Note that the  $x0.1 \Omega$  decade is subtractive.

(Courtesy Leeds and Northrup Co., North Wales, Pennsylvania)

would result in a slightly different balance. The correct measured resistance of the thermometer coil alone, which is what is wanted, is as follows, where  $R_1$  is the result of the first balance and  $R_2$  is the result of the second balance:

$$R_1 + C = RT + T, \text{ or } R_1 = RT + T - C$$

where  $RT$  is the resistance of the thermometer coil alone, and

$$R_2 + T = RT + C, \text{ or } R_2 = RT + C - T$$

The average, then, is

$$\begin{aligned} (R_1 + R_2)/2 &= RT + T - C + RT + C - T \\ &= 2RT/2 = RT \end{aligned}$$

In the manufacture of most SPRTs care is taken to adjust lead resistances so that the difference in balance between the normal and reversed position of the commutator switch requires, usually, adjustment of only the lowest dial.

Two design characteristics of the Mueller Bridge are elegant enough to be worth noting. The first is the nature of the decade switches, which must be constructed so as to be free from unwanted contact resistances, even though on the lowest dial the increment of resistance (on the L&N G-3 Bridge) is  $10\mu\Omega$  ( $0.00001 \Omega$ ). No physical switch has contact resistances which would not represent an uncertainty of many times that level (the best switches, properly maintained and lubricated, are not better than  $0.001 \Omega$  uncertain), and the friction of switching frequently generates spurious and transient thermal emfs. Nor is it possible to make fixed decade resistors of micro-ohm values. The lower decades of the Mueller bridge,  $\times 0.1 \Omega$  and lower, employ Waidner-Wolff decades.

When a shunt is applied to a resistor, the change in resistance  $\delta R$  is

$$\delta R = R - RS/(R + S) = R^2/(R + S)$$

The reduction in resistance from that of the unshunted resistor is

$$(10 - n)\delta R;$$

$$R^2/(R + S) = (10 - n)\delta R$$

and the shunt required is



$$S = [(R^2/(10 - n)\delta R) - R$$

Fig. 11 shows a Waidner-Wolff decade, in which a fixed series resistor,  $R_s$ , is shunted by shunts,  $R_1...R_{10}$ , that can be varied in 11 steps from 0 to infinity.  $R_s^2$  should be exactly divisible by all the integers below 10. One possible value for  $R_s^2$ , used in the Figure, is 50.4. The minimum shunt resistance is obtained when the switch is set at 0; for the X0.0001  $\Omega$  decade,  $R_1 = 50.4 - \sqrt{0.0504}$ .

FIGURE 11

## A Waidner-WOLFF DECADE OF A MUELLER BRIDGE

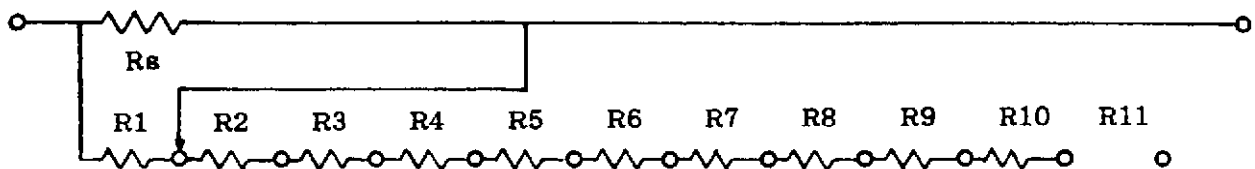

Resistors  $R_1$  through  $R_{11}$  are the same for all decades. They shunt  $R_s$ , adding one increment of resistance per dial step. The values shown are one of a number of possible sets of value.

For all decades:

$R_2 =$	5.6 $\Omega$
$R_3 =$	7.0 $\Omega$
$R_4 =$	9.0 $\Omega$
$R_5 =$	12.0 $\Omega$
$R_6 =$	16.8 $\Omega$
$R_7 =$	25.2 $\Omega$
$R_8 =$	42.0 $\Omega$
$R_9 =$	84.0 $\Omega$
$R_{10} =$	252.0 $\Omega$
$R_{11} =$	$\infty$

Specific to the decade shown:

Decade	$R_s$	$R_1$
x 0.1	$\sqrt{50.4}$	$50.4 - \sqrt{50.5}$
x 0.01	$\sqrt{5.04}$	$50.4 - \sqrt{5.04}$
x 0.001	$\sqrt{0.504}$	$50.4 - \sqrt{0.504}$
x 0.0001	$\sqrt{0.0504}$	$50.4 - \sqrt{0.0504}$

Note that with all dials set at 0, the value of the decade string is not zero. This non-zero resistance is balanced by an equal and trimmable resistor in the opposing arm of the bridge.

If the ratio  $R^2/\delta R$  is made the same for all decades, then identical sets of fixed coils per step may be used for all decades. The resistances which must be put in series with the  $R_1$ , when  $R_s^2 = 50.4$ , are shown in Fig. 11

The effect of this arrangement is to place a large resistance in series with any sliding switch contact, so that variations in contact resistance are negligible. The sum of the decades in their zero positions is, however, not zero but is the sum of the resistances in series with the sliding contacts, in the example of Fig. 11, 9.167  $\Omega$ , and a compensating resistor is inserted into the opposite leg of the bridge to exactly balance this residual resistance.

A second feature of the Mueller bridge is provision for self-calibration. Since there are 11 positions on each decade switch (0 through X = 10) any resistance which is the maximum resistance of a dial is the resistance of the first step of the next higher dial. The bridge can be self-calibrated in terms of internal bridge units using no more equipment than a stable decade resistance box, and to calibrate in terms of absolute ohms, only one standard resistor, preferably 10  $\Omega$ , is necessary. The technique is described in manufacturers' manuals. It consists simply in first setting a decade dial to 1 and the next lower decade to 0, using the next lower dials to balance an appropriate input resistance; and then, without changing the external resistance, setting the decade dial to 0 and the next lower dial to X, rebalancing with the lower dials, and noting the difference. Thus each step of the bridge dials can be compared with the next lower dial, and finally the lower dial can be calibrated in terms of galvanometer deflection.

## 6: DIGITAL OHM METERS

It is tempting to think of multi-digit high-resolution ohm meters as readouts for SPRTs. In general, they are not satisfactory. Most  $8\frac{1}{2}$  and  $9\frac{1}{2}$  digital ohm meters present much more current through the thermometer than the 1 mA level which is the accepted level for calibration, and none that I know of permit two current levels (say 1 mA and  $\sqrt{2}$  or 1.414 mA) which would allow the desirable extrapolation to zero-power resistance, to eliminate the effects of  $I^2R$  heating. (As an aside, this qualification becomes even more important for a user who measures the resistance of industrial temperature sensors of low dissipation, such as small industrial PRTs and thermistors).

## 7: A PRECISION CURRENT COMPARATOR WITH DC THERMOMETER EXCITATION

All conventional dc bridges, such as the Mueller Bridge, depend upon a number of decades of precision fixed resistors. Such resistors are subject to drift in value, due to a number of factors; strain or the relief of residual strain, impressed current, atmospheric and other contamination. Recalibrations are not difficult to do, using equipment generally

available in the laboratory and one stable fixed resistor of known characteristics, but must be done at appropriate and perhaps frequent intervals. The resistors themselves have temperature coefficients. Attempts to eliminate temperature effects by thermostating the bank of resistors leads to the generation of thermal e.m.f.s at the junctures of resistance alloys and copper circuitry wiring; the tradeoff is the need to make temperature corrections.

An alternative to decade resistors is decade inductors. Toroidally wound inductive dividers and transformers provide a means for generating very accurate ratios of voltage or current equal to an integer ratio of turns. Since there is no such thing as dc inductance, bridges which use inductors require ac excitation, which may be at low frequencies. In theory, at least, the position of a tap on a well-made inductor is fixed and stable; if the entire inductor is isothermal the tap position should be effectively unchanged with environmental changes. Any thermals generated are dc and cancel in ac circuitry.

Based on the work of Kusters et al (7) at the National Research Council (Canada), Guildline developed its Model 9975 Precision Current Comparator. This comparator is unique among modern bridges in that, while the inductors require ac, the signal applied to the galvanometer is dc. The principle is simple, although the execution is sophisticated, and is illustrated in Fig. 12. There are three windings on a high-permeability toroidal core, suitably shielded electrostatically and magnetically. If ampere turns  $I_1N_1$  and  $I_2N_2$  are equal and opposite (that is, in a condition of balance) there will be zero flux in the core and consequently zero voltage induced in the detector winding. However in practice, the primary and secondary currents of a current transformer are never exactly equal. A special core design makes it possible, in the 9975, to adjust to zero flux with a small compensating current.

The operation is as follows. Current from a power supply flows through an adjustable number of turns of the comparator ( $N_x$ ) and through the thermometer ( $R_x$ ). A second current flows through a fixed number of turns ( $N_s$ ) and through the reference resistor ( $R_s$ ). When the bridge is in balance, both the net ampere-turns imposed on the comparator cores, which are indicated on an ampere-turn balance meter, and the difference between the voltages across the thermometer and the reference resistor, as measured by the sensitive light-beam galvanometer, must not change as the currents through both are reversed. Reversal may be automatic, at a selected rate, or manual. This bridge is capable of measurements of 1 part in 10 million, and its expected accuracy and stability is 2 parts in 10 million. It requires manual manipulation of the decade dials; its balance and rebalance is not automatic.

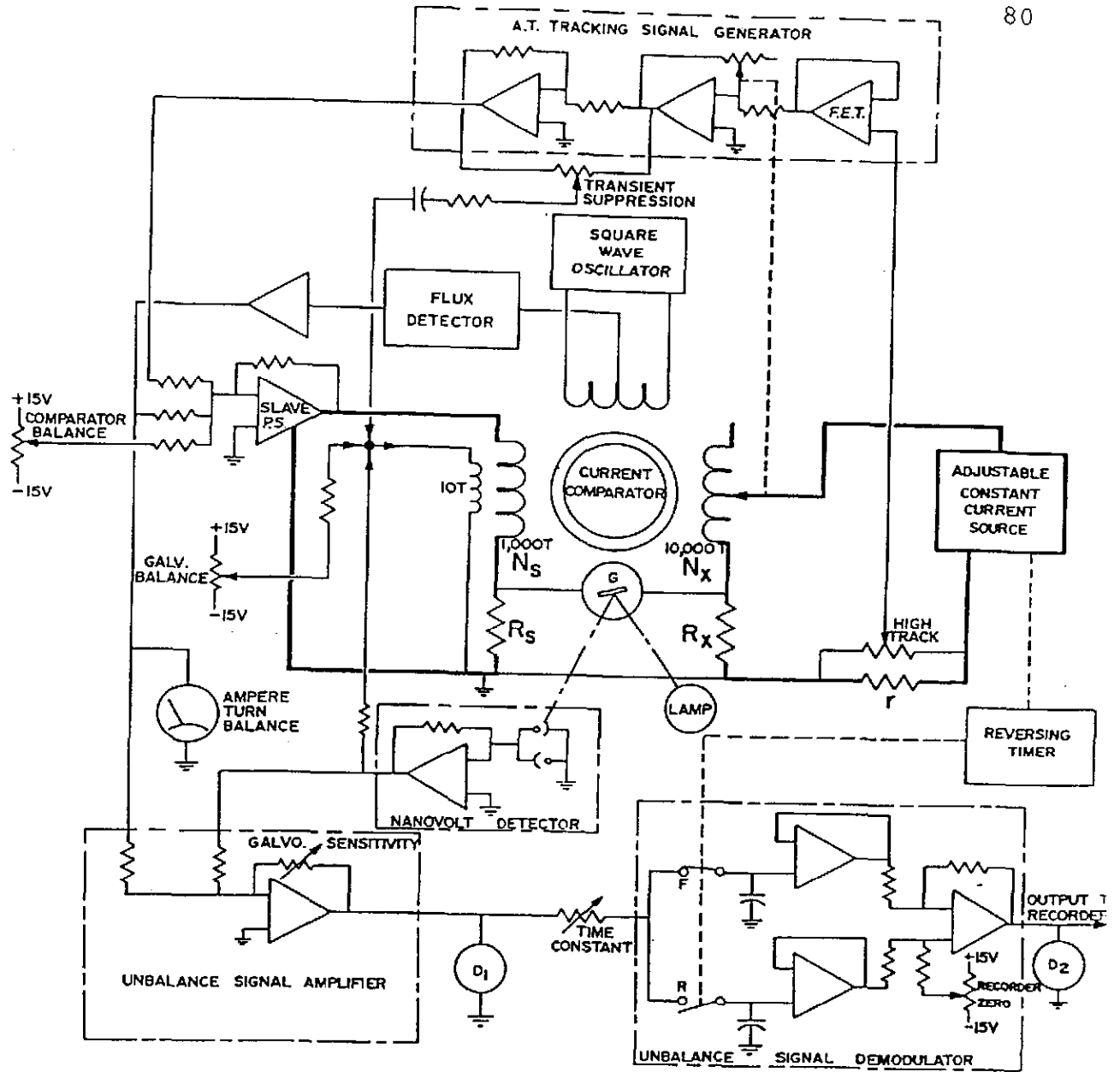

FIGURE 12

The circuit schematic of the Guildline Model 9975 Direct Current Comparator.

(Courtesy Guildline Instruments Inc., Orlando, Florida and Smith Falls, Ontario, Canada)

## 8: A NEW AUTOMATIC DC CURRENT COMPARATOR

A relative newcomer to the field is the Measurements International Model 6010A DC Resistance Thermometer Bridge (8), announced at the annual meeting of the National Conference of Standards Laboratories, Albuquerque, N.M. in 1991. The bridge appears to be a dc current comparator rather like the Guildline 9975, except automatically balanced. (It does not seem to have the capability to operate in the off-balance mode, needed to make a chart recorder sweep). According to Duane Brown, VP Operations, the  $2\sigma$  uncertainty of the bridge is better than 0.1 ppm + 1 least significant bit and linearity and resolution are specified as 0.01 ppm. The measurement range is 0.1  $\Omega$  to 10 k $\Omega$  full-scale, and provides ratio ranges from 0 to 10  $R_x/R_s$ . A suitable number of thermometer current choices are provided, all of which may be multiplied by  $\sqrt{2}$ . I have not had an opportunity to see or use this bridge.

## 9: AN AC AUTOMATIC OR MANUALLY-BALANCED BRIDGE

Automatic Systems Laboratories has developed a line of bridges which can be used in a truly automatic-balance mode, or manual balance may be selected (9). (The latter is most handy to have, for it is often desirable to operate a bridge in a condition of unbalance approaching balance; e.g., when a chart record is being made of a rising temperature).

The ac carrier of the F-17 bridge is fixed at  $1\frac{1}{2}$  line frequency; for 50 Hz supplies at 75 Hz, and for 60 Hz supplies at 90 Hz. This choice allows maximum rejection of noise from the line and from active circuit components, while providing maximum detector bandwidth. The more sophisticated F-18 operates at  $\frac{1}{2}$  and  $1\frac{1}{2}$  line frequency (25 Hz and 75 Hz for 50 Hz supplies and 30 Hz and 90 Hz for 60 Hz supplies) selectable. This feature allows the estimate of any effects on the measurement due to carrier frequency, and extrapolation to dc where necessary.

A block diagram of the F-17 and F-18 bridges is shown in Fig. 13. A stable ac signal is produced by a carrier generator current source. This drives current through the standard resistor and the unknown resistor, which are connected in series. The voltage generated across  $R_s$  is used as the reference signal to excite the input windings of a multistage inductive divider. The inductive divider's secondary output is compared with the voltage appearing across the unknown resistor  $R_x$ , in this case, the SPRT, by the detector circuitry. The inductive divider acts as a precision ratio transformer. Its taps are adjusted to balance (that is, to bring to zero) the output to the detector circuit. At balance, the voltage from the inductive divider is exactly equal and opposite to that appearing across  $R_x$ . The output of the inductive divider is also a precise ra-

F17 and F18 Schematic

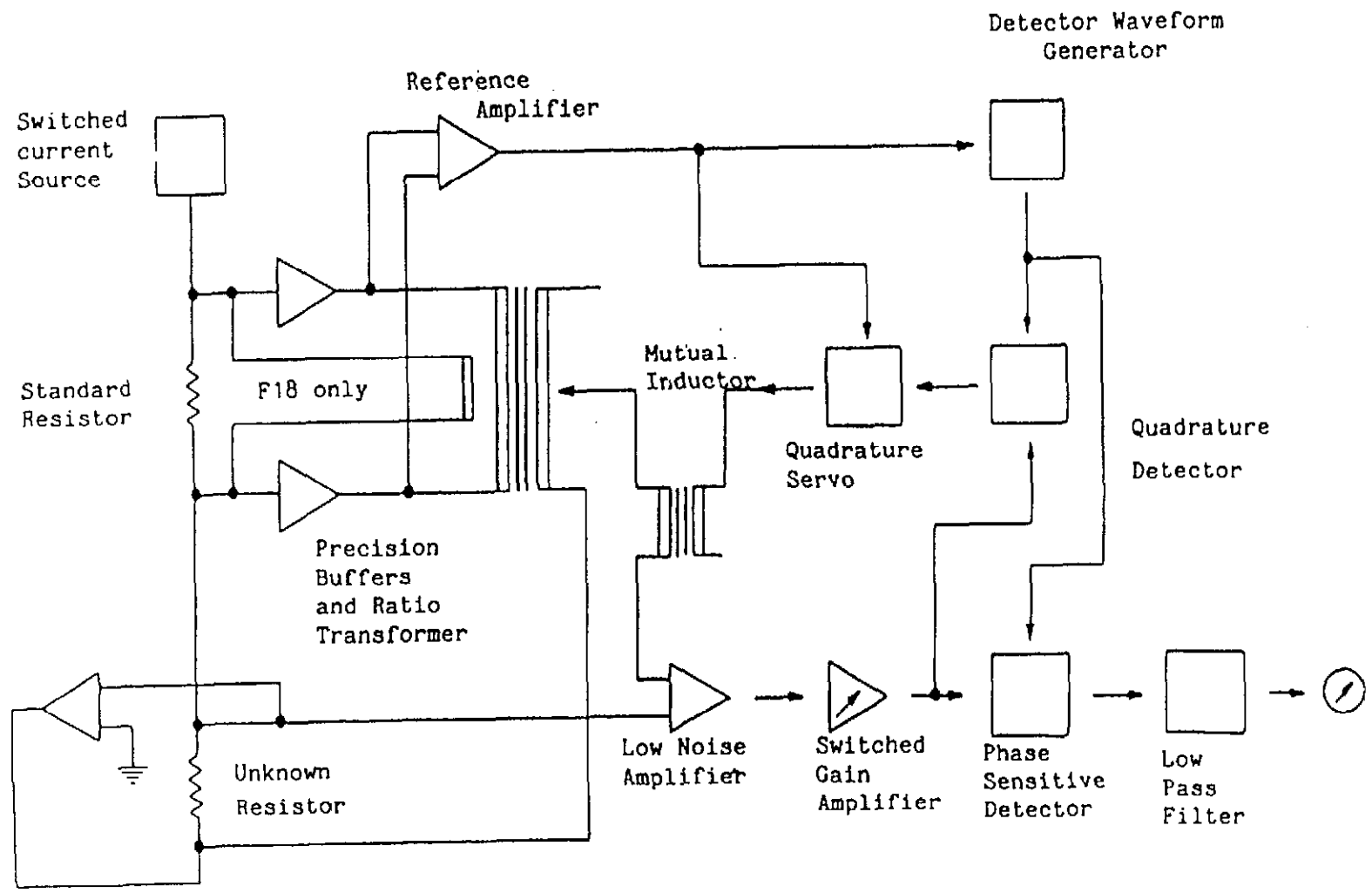

FIGURE 13

THE ASL F-17 AND F-18 AUTOMATIC BRIDGES

Courtesy Automatic Systems Laboratories Ltd.



Automatic Systems Laboratories Ltd  
28 Blundells Road, Bradville  
Milton Keynes MK11 7HF, England  
Tel: 0908-320666  
Fax: 0908-322564  
Telex: 826349 ASLAB G

tio of the voltage across  $R_s$ . Since the current flowing through  $R_s$  and  $R_x$  is identical, the ratio set on the inductive divider is equal to the ratio  $R_x/R_s$ .

The nominal accuracy of the F-17 bridge is 1ppm, and of the F-18, 0.1ppm. The F-18 is optimized specifically for SPRT values of 100, 25.5, 2.5 and 0.25  $\Omega$ . The F-18 has  $7\frac{1}{2}$  decades, and reads resistance ratios over the range 0.000 000 0 and 1.299 999 9. A generous selection of operating sensitivities and of thermometer currents (from 0.1 mA to 50 mA rms, (F-18) including a  $\sqrt{2}$  multiplier) are supplied.

#### IMPORTANT REFERENCES

In this text, I have relied, as I have for many years, upon two important references on fixed resistors and resistance measurement. These are:

Frank A. Laws, *Electrical Measurements*, 2nd Edition, McGraw Hill Publishing Co., New York, 1938

Forest K. Harris, *Electrical Measurements*, John Wiley & Sons, New York, Chapman and Hall, London, 1956

#### FOOTNOTES

(1) Norman B. Belecki, Ronald F. Dziuba, Brice F. Field, Barry N. Taylor, Guidelines for implementing the new representations of the volt and the ohm effective January 1 1990, NIST Technical Note 1263 (1989)

(2) James L. Thomas, *A new design of precision resistor standard*, Bur. Standards Jour. Research, Vol 5 (1930)

(3) F. J. Wilkins, M. J. Swan, *Precision ac/dc resistance standards*, Proc. IEEE, Vol 117, No. 4 (1970)

(4) [H. Tinsley Ltd, Standards House, Croyden, Surrey, CRO 4RR, England]

(5) E. F. Mueller, *Wheatstone bridges and some accessory apparatus for resistance thermometry*, Nat. Bur. Stand. Bull., 13, 547 (1916)

(6) Leeds and Northrup Models 8067 (G-1), 8069B (G-2) and 8071B (G-3) Mueller Bridges, respectively. [Leeds and Northrup Company, North Wales, Pennsylvania USA]

(7) N. L. Kusters, M. P. McMartin and R. J. Berry, *Resistance Thermometry with the direct current comparator*, Temperature, Its Measurement and Control in Science and Industry, Vol 4 p 1477, Instr. Soc. Am (1972) and *A direct current comparator bridge for*

*resistance thermometry*, Guildline Instruments [Guildline Instruments Inc., 4403 Vineland Road, Suite B-10, Orlando Florida USA 32811; also Smith Falls, Ontario, Canada]

(8) [Measurements International, PO Box 2359, Prescott, Ontario, Canada and SW Murray Boulevard, Beaverton Oregon 97006, USA]

(9) Models F-17 and F-18 [Automatic Systems Laboratories Ltd., 28 Blundells Road, Bradville, Milton Keynes MK13 7HF, England]